

UNIMAC CHECK VALVES

Dual Plate Check Valve

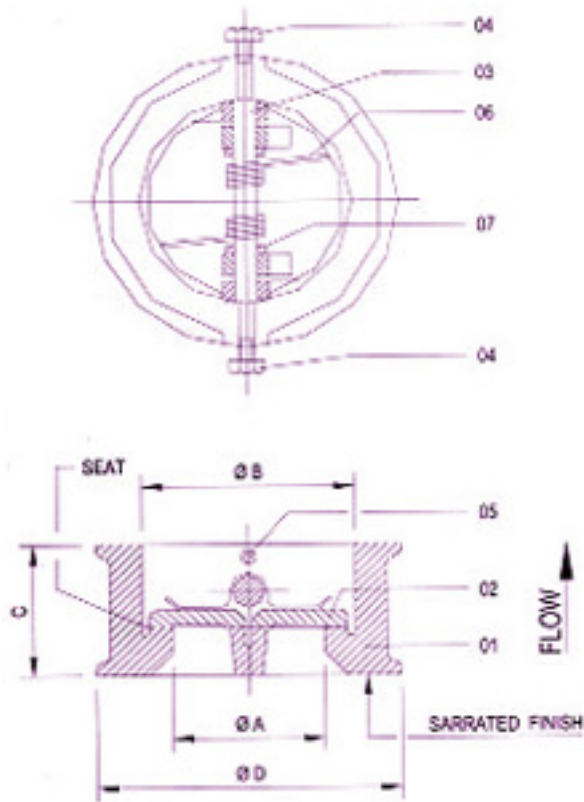

Technical Data

Manufacturing STD	:	API 594
Testing & Inspection STD	:	API 598
Face to face	:	API 594

No.	Description	Material	Qty.
01	Body	C.I. IS : 210 GR. FG 200/ ASTM A 216 GR WCB	1
02	Disc	AISI 304 /G.M.	2
03	Hinge Pin	AISI 304 /AISI 316	1
04	Plug	AISI 304 /AISI 316	2
05	Stop Pin	AISI 304 /AISI 316	1
06	Spring	AISI 304 /AISI 316	2
07	Bearing	AISI 304 /AISI 316	1

Suitable for Water and oil

Test Pressure Bar

class	Shell	Seat
150	21	11

Class -150

Size	øA	øB	øC	øD
50	51	50	60	105
65	66	75	67	124
80	75	90	73	134
100	101	115	73	172
125	126	135	83	196
150	151	165	98	220
200	199	220	127	276
250	251	265	146	338
300	299	320	181	407
350	351	350	184	448
400	401	400	191	514
450	451	450	203	549
500	501	500	219	603
600	599	600	222	718

Note : Due to constant up gradation, dimensions are subject to change by the manufacturer.