

MAXIMUS

Completion Systems

LINER HANGER SYSTEMS

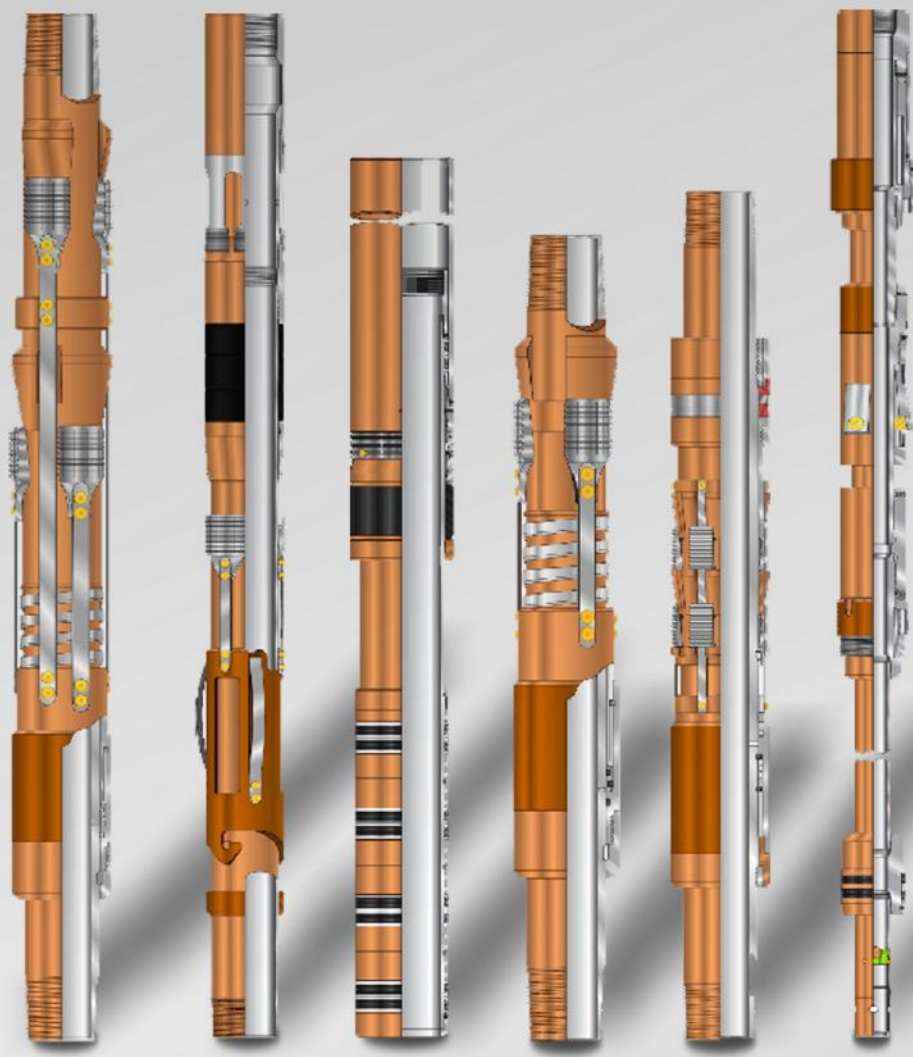

Quartus Liberty Liner Hangers Single & Dual Cone Versions (Enclosed Slips)

Quartus Liberty Liner Hangers have the ability to be rotated and/or reciprocated to bottom of well without fear of premature setting of the hanger slips due to enclosed & protective pockets which cover the slips till their roots and the slip wickers do not touch the surface directly.

In other words, the design features a completely enclosed piston, setting sleeve and slip spring arrangement that prevents debris from setting in and around them, preventing a possible hanger failure.

The Quartus Liberty Liner Hangers are available in both single and dual-cone version, the single-cone design allows for maximum bypass for circulating while maintaining the ability to hang short to medium length liners. The dual-cone design provides even greater bypass area and is capable of hanging medium to long liners.

The Quartus Liberty Liner Hangers are hydraulic set type.

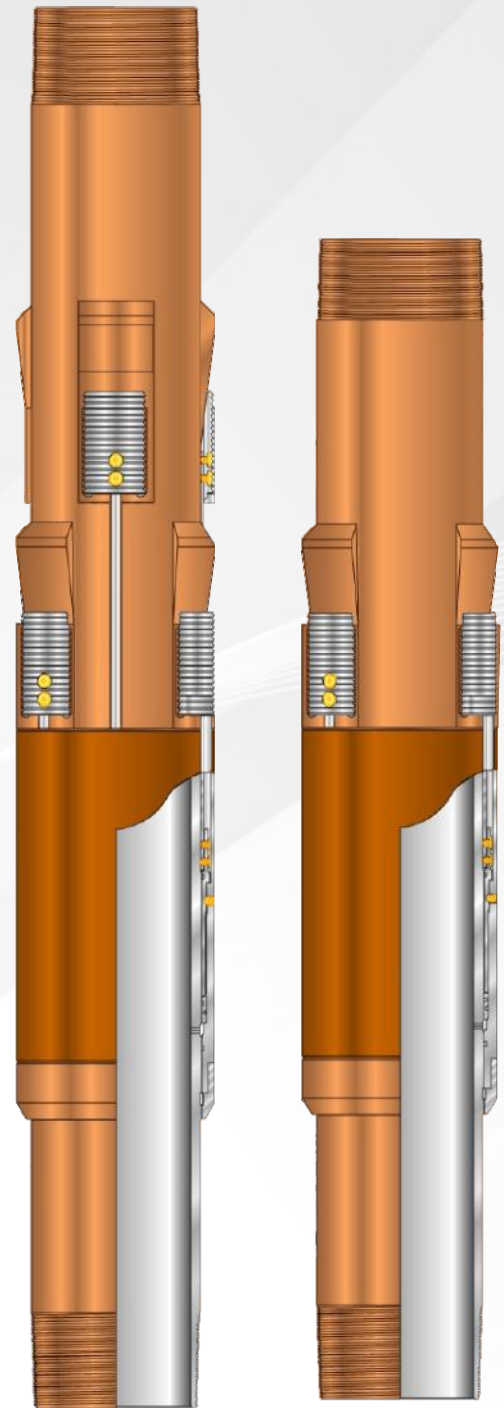

Quartus Liberty Liner Hangers
Single & Dual Cone Versions (Enclosed Slips)

Technical Specifications

Liner Size O.D.	Casing Size		Maximum Body O.D.
	O.D.	Weight Range	
4 ½	7	20.0 - 32.0	5 27/32
5	7 5/8	33.7 - 39.0	6 3/8
5 ½	7 5/8	26.4 - 33.7	6 ½
		33.7 - 39.0	6 3/8
7	9 5/8	43.5 - 53.5	8 1/4
7 5/8	9 5/8	43.5 - 47.0	8 3/8
		53.3	8 1/4
9 5/8	11 3/4	60.0 - 65.0	10 3/8
	13 3/8	68.0 - 72.0	11 3/4
11 3/4	13 3/8	68.0 - 72.0	12 1/16
13 3/8	20	169	17 1/8

