

# GDM150H/250H

- ▶ Smallest dimensions in the hydraulic market
- ▶ Available in 400hp and 600hp motor options
- ▶ Powerful torque with compact design

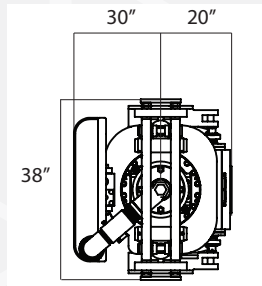

MODEL	GDM150H	GDM250H
LOAD RATING	150 TON	250 TON
BREAKOUT TORQUE	32,000	32,000
CONTINUOUS TORQUE (LSHT)	22,000	26,000
CONTINUOUS TORQUE (HSLT)	14,200	14,200
MAX SPEED (RPM)	200	200
MOTOR HORSEPOWER	400 HP	600 HP
HOOK WEIGHT	14,000 LBS	16,000 LBS
MUD PATH	5000 PSI (OPTIONAL: 7500 PSI) STANDARD 3"	

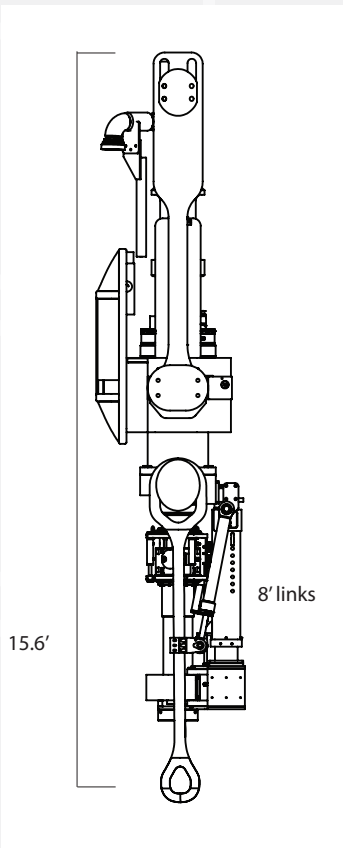